

- 1 PLATED WITH 0.76μm [.000030] GOLD ON INSIDE OF LOCALIZED GOLD PLATE AREA, GOLD FLASH ON REMAINDER, ALL OVER 1.27μm [.000050] NICKEL UNDERPLATE.
-OR-
GOLD FLASH OVER PALLADIUM-NICKEL 0.76μm [.000030] TOTAL ON INSIDE OF LOCALIZED GOLD PLATE AREA, GOLD FLASH ON REMAINDER, ALL OVER 1.27μm [.000050] NICKEL UNDERPLATE.
- 2 PLATED GOLD FLASH PER MIL-G-45204 OVER 0.76μm [.000030] MIN NICKEL PER QQ-N-290.
- 3 SELECTIVE GOLD PLATED 0.76μm [.000030] THICK PER MIL-G-45204 ON MATING END FOR A LENGTH OF 2.54 [.100], TIN PLATED WIRE BARRELS, ALL OVER 1.27μm [.000050] NICKEL PER QQ-N-290.
- 4. FOR USE WITH MIN-APPLICATOR.

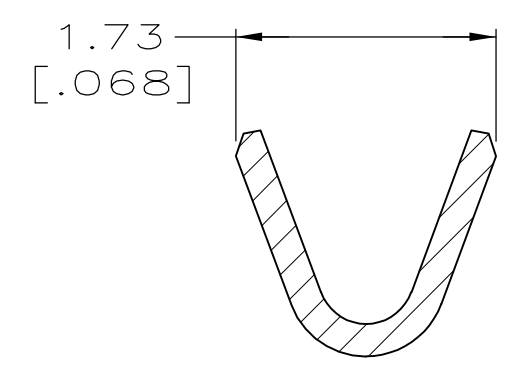
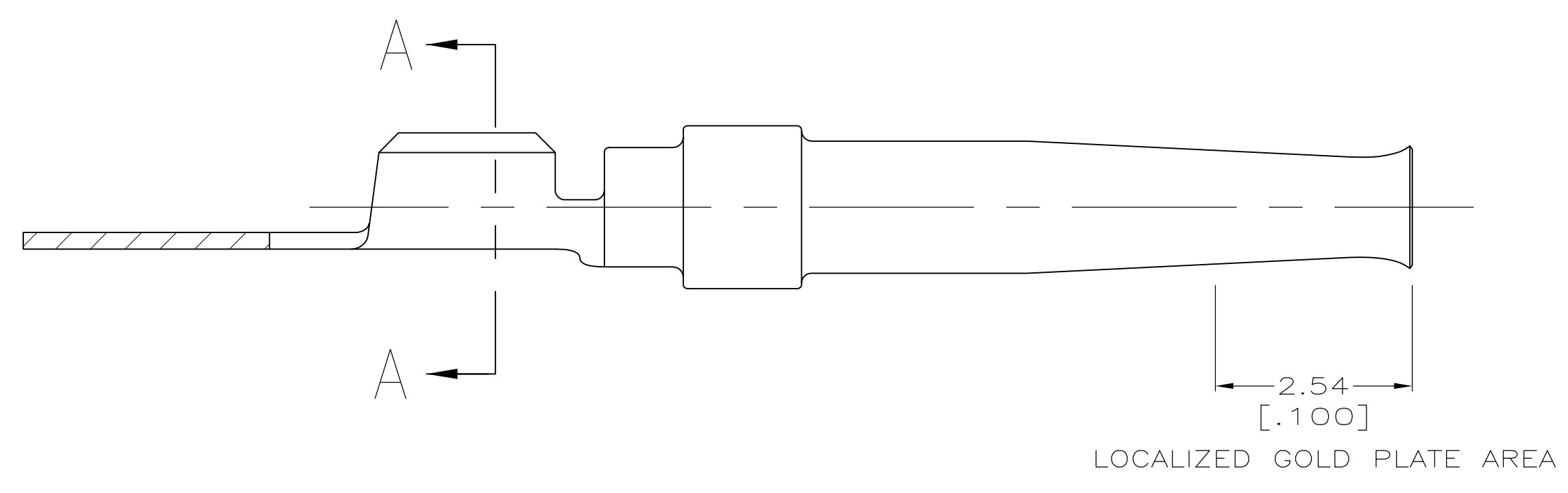

SECTION A-A
SCALE 20:1

SUPERSEDED BY 205311-3	3	2-205311-1
	2	205311-4
	1	205311-3
FINISH		PART NO

THIS DRAWING IS A CONTROLLED DOCUMENT.		DWN L. MORNINGSTAR 1-12-70	Tyco Electronics Corporation Harrisburg, PA 17105-3608	
DIMENSIONS: mm [INCHES]		CHK J. SAYLOR 1-14-71	NAME R. BAER 1-14-71	
TOLERANCES UNLESS OTHERWISE SPECIFIED:		PRODUCT SPEC		
0 PLC	± -	APPLICATION SPEC		
1 PLC	± -	SIZE		
2 PLC	± 0.13 [.005]	CAGE CODE		
3 PLC	± -	DRAWING NO		
4 PLC	± -	RESTRICTED TO		
ANGLES	± -	A1 00779 ©=205311		
FINISH	SEE TABLE	WEIGHT		
MATERIAL COPPER ALLOY		CUSTOMER DRAWING		
		SCALE 15:1 SHEET 1 OF 1 REV S		